

**P/N: 15085 EMP®**

1	CS1 HD Front Winch Bumper	4	10-1.50mm x 35mm Hex Bolts
1	Winch Tray Assembly	4	10mm x 34mm x 3mm Large Flat Washers
1	Long Mesh Fill Panel	2	10mm x 24mm x 2.2mm STD Flat Washers
2	Outer Mesh Fill Panels	2	10mm x 20mm x 2mm Large Flat Washers
2	Bumper Support Brackets	4	10mm Lock Washers
1	Active Air Dam Relocation Bracket	2	10-1.5mm Hex Nuts
1	Active Air Dam Top Support Bracket	4	10-1.5mm Nylon Lock Nuts
2	Active Air Dam Relocation Bracket Spacers	1	8-1.25mm x 50mm Hex Bolts
1	Driver/left side LED "L" Bracket	4	8-1.25mm x 25mm Hex Bolts
1	Passenger/right side LED "L" Bracket	2	8-1.25mm x 25mm Stainless Steel Hex Bolts
1	License Plate Bracket	14	8mm x 24mm x 2mm Flat Washers
2	Plastic License Plugs	6	8mm Lock Washers
2	25mm x 15.5mm x 2mm Sensor Washers	1	8-1.25mm Nylon Lock Nut
2	Plastic Sensor Hole Plugs	4	8-1.25mm Hex Nuts
2	Edge Trims	2	8-1.25mm Flange Nuts
2	12mm/10mm Double Nut Plates	14	6-1.0mm x 20mm Button Head Combo Bolts
2	12mm Spacer Washers	1	6-1.0mm x 20mm Button Head Bolt
2	12-1.75mm x 110mm Hex Bolts	1	6-1.0mm x 50mm Hex Bolt
8	12-1.75mm x 35mm Hex Bolts	4	6mm x 18mm x 1.6mm Flat Washers
2	12mm x 37mm x 3mm Flat Washers	2	6mm Nylon Lock Nuts
8	12mm x 32mm x 3mm Flat Washers	3	6mm Flange Nuts
10	12mm Lock Washers	10	Nylon Wire Ties
2	12mm Hex Nuts	1	6mm Hex Wrench
2	10-1.50mm x 30mm Button Head Bolts	1	4mm Hex Wrench

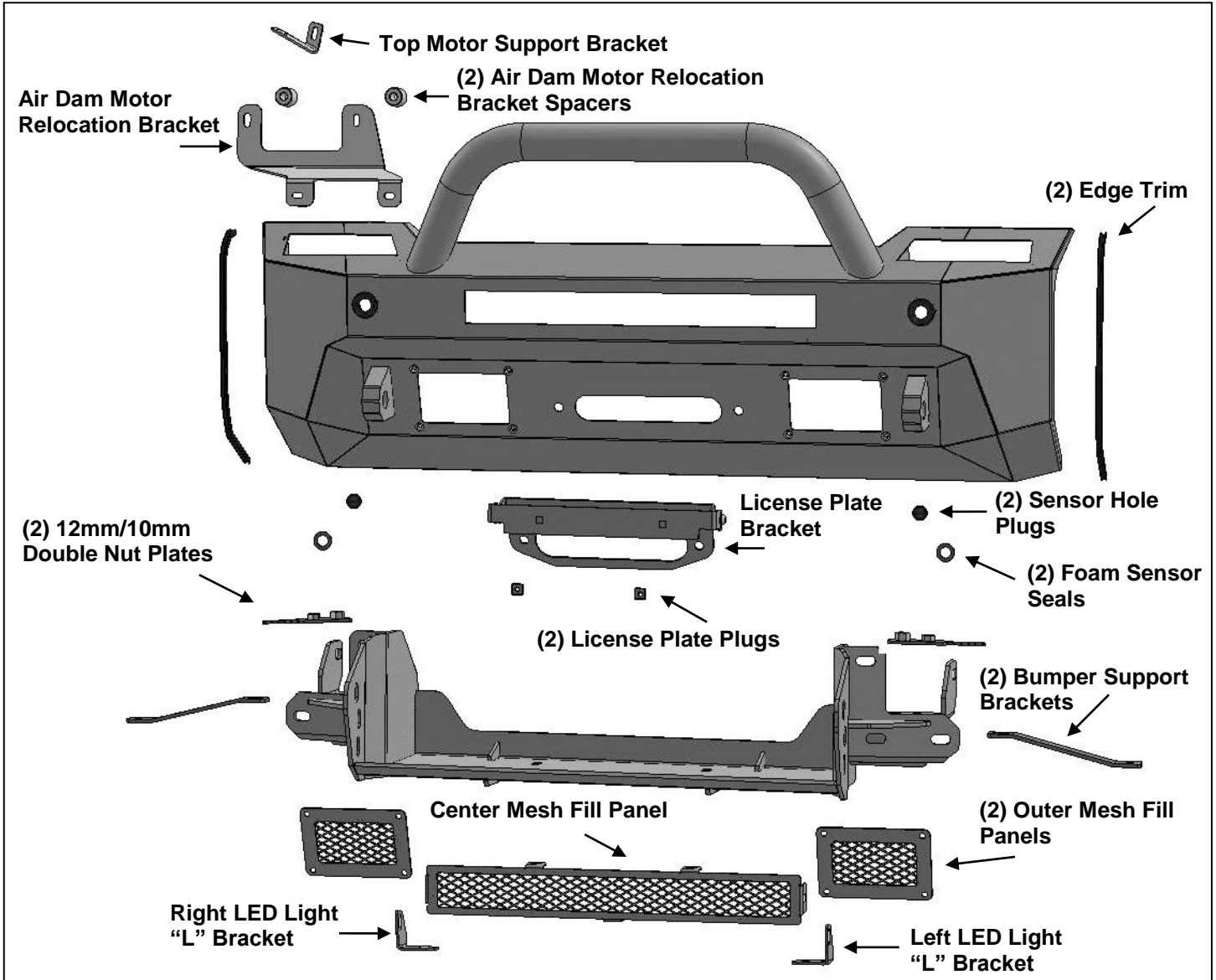

**PROCEDURE:**

**REMOVE CONTENTS FROM BOX. VERIFY ALL PARTS ARE PRESENT. READ INSTRUCTIONS CAREFULLY BEFORE STARTING INSTALLATION. BUMPER IS HEAVY, ASSISTANCE IS HIGHLY RECOMMENDED TO AVOID POSSIBLE INJURY OR DAMAGE TO THE VEHICLE. CUTTING IS REQUIRED.**

1. Move to the driver/left wheel opening. Remove the hardware attaching the inner fender liner to the back and bottom of the outer end of the front bumper and fender, **(Figure 1)**. Also pull the end of the fender flare (if equipped) to release the flare from the bumper cover, **(Figure 2)**. **NOTE:** Do not remove the fender flare, only release the forward end of the flare from the bumper cover. Repeat this **Step** to remove the hardware and release the flare from the passenger/right side of the vehicle.
2. Remove the license plate. Remove the hardware attaching the bottom of the bumper cover to the vehicle, **(Figure 3)**. Remove the lower panel from the bottom of the bumper cover, **(Figure 4)**.
3. Remove the center body panel (fascia panel) below the grille, **(Figure 5)**.
4. Open the front hood and unplug all harnesses leading to the driver/left and passenger/right side of the grille and front bumper, **(Figure 6)**.

5. Remove the hardware attaching the top of the grille to the radiator core support, **(Figure 7)**. With assistance, carefully pull the grille and bumper cover off as an assembly, **(Figure 8)**. To avoid damage to the finish, place bumper assembly on a soft surface.
6. Unplug the wiring harness leading to the active air dam motor, **(Figure 9)**. Remove the aluminum impact bumper, **(Figures 10 & 11)**.
7. Remove the active air dam from the air dam motor, **(Figure 12)**. Next, remove the motor assembly from the back of the impact bumper, **(Figure 12)**.
8. Remove the plastic cover from the motor assembly. Cut the air dam bracket off of the mounting drum, **(Figure 13)**.

**Optional-requires partial motor disassembly to cut air dam bracket:**

- a. Remove the long cross pivot bolt, **(Figure 14)**.
  - b. Remove the outer caps, inner drive cups and spring, **(Figures 15 & 16)**.
  - c. Slide air dam mount out of pivot bracket, **(Figures 17 & 18)**.
  - d. Cut bracket off of air dam mount, **(Figure 19)**.
  - e. Reassemble motor assembly.
9. Move to the grille opening. Locate the water hose running across the center of the grille opening, **(Figure 20)**. Release hose from center bracket. Remove the hex nuts attaching the hose mounting brackets at the ends of the hose and pull the brackets off of the threaded studs, **(Figures 21 & 22)**. **IMPORTANT:** Do not disconnect the hose, only move the brackets on the hose off of the studs.
  10. Remove the hex bolt attaching the center vertical core support bracket to the front of the lower crossmember, **(Figure 23)**. Pull the bracket outward and slide the hose under and behind the support bracket, **(Figure 24)**. Reattach the hose brackets and secure the hose to the back of the support.
  11. Select the air dam motor assembly and Relocation Bracket. Attach the bottom of the motor assembly to the back of the Relocation Bracket and Bracket Spacers with (1) 6mm x 50mm Hex Bolt, (2) 6mm Flat Washers, (1) 6mm Nylon Lock Nut, (1) 8mm x 50mm Hex Bolt, (2) 8mm Flat Washers and (1) 8mm Nylon Lock Nut, **(Figure 25)**. Insert the (2) Bracket Spacers between the back of the Relocation Bracket and the tabs on the motor assembly.
  12. Slide the bottom of the Relocation Bracket between the core support bracket and the crossmember. Attach the bottom of the Relocation Bracket to the front of the lower crossmember and support bracket with the included (2) 6mm Button Head Combo Bolts, **(Figures 25 & 26)**.
  13. Remove the hex bolt from the passenger/right side of the hood release, **(Figure 27)**. Select the Upper Support Bracket. Attach the Bracket to the hood release and core support with (1) 6mm x 20mm Button Head Combo Bolt, **(Figure 28)**. Attach the Bracket to the top of the motor assembly with (1) 6mm x 20mm Button Head Bolt, (2) 6mm Flat Washers and (1) 6mm Nylon Lock Nut, **(Figures 28 & 29)**.
  14. Plug wiring harness into air dam motor. Tighten all Relocation Bracket and hose mounting hardware.
  15. Select the Winch Tray assembly, **(Figure 30)**. Depending on model and size of winch, it may be necessary to attach winch to Winch Tray before installing Tray.
  16. With assistance, lift the Winch Tray up into position. Reuse the (4) factory hex bolts to attach the bottom of the Winch Tray to the end of the frame, **(Figure 30)**. Leave hardware loose. Use the included (2) 10mm x 35mm Hex Bolts, (4) 10mm x 34mm Large Flat Washers, (2) 10mm Lock Washers and (2) 10mm Hex Nuts to attach the top of the Winch Tray to the end of the frame, **(Figures 30 & 32)**. Snug but do not fully tighten hardware at this time.
  17. Attach the bracket on the driver/left side of the Winch Tray to the side of the frame with the included (1) 12mm x 110mm Hex Bolt, (1) 12mm x 37mm Large Flat Washer, (1) 12mm Large Spacer Washer, (1) 12mm Lock Washer and (1) 12mm Hex Nut, **(Figures 31 & 32)**. **IMPORTANT:** Use the 12mm Large Spacer Washer to cover the large hole on the inner facing side of the frame. Don't fully tighten hardware at this time.
  18. Select (1) Double Nut Plate, **(Figure 33)**. Insert the Nut Plate into the opening in the end of the frame. Line up the Nut Plate with the (2) holes in the bottom of the frame. Attach the bottom of the Winch Tray to the bottom of the frame and Nut Plate with (1) 12mm x 35mm Hex Bolt, (1) 12mm Lock Washer and (1) 12mm x 32mm STD Flat Washer, **(Figure 34)**. Select (1) Bumper Support Bracket. Attach the inner end of the Support Bracket to the bottom of the Winch Tray and Nut Plate with (1) 10mm x 35mm Hex Bolt, (1) 10mm Lock Washer and (1) 10mm x 24mm STD Flat Washer, **(Figure 35)**. Leave loose.
  19. Repeat **Steps 17 & 18** to attach the passenger/right side of the Tray and Support Bracket to the frame.

20. Move to the factory grille and bumper assembly. Models with parking sensors, remove the (2) inner sensors, **(Figure 36)**. Release the clips attaching the wiring harnesses and move the harnesses out of the way. Disassemble grille and bumper to isolate the inner plastic bumper support, **(Figure 41)**.
21. Use removable tape (masking tape) to create a vertical, straight line following the bend in the driver/left side of the bumper reinforcement, **(Figure 37)**. Use the tape to draw a line 3/4" in from the top edge below the driver/left fog light, **(Figure 38)**. Move out to the corner above the sensor if equipped. Use the tape to mark a straight line across the bumper reinforcement along the corner, **(Figures 39—41)**. Repeat the previous **Steps** to mark the passenger/right side of the plastic reinforcement. Use a sharp knife or hacksaw blade to cut along the previously marked path, **(Figure 41)**. **WARNING:** Make sure all wiring harnesses are clear before cutting bumper reinforcement.
22. Reassemble the grille/bumper assembly. Reattach the wiring harnesses but leave the sensor harness loose from the back of the grille. Reinstall the grille/bumper assembly, **(Figure 42)**.
23. Attach the outer end of the driver/left Bumper Support Bracket to the hole in the back of the factory bumper cover with (1) 8mm x 25mm Hex Bolt, (1) 8mm Lock Washer, (1) 8mm Flat Washer and (1) 8mm Flange Nut, **(Figures 43 & 44)**. Leave hardware loose. Repeat this **Step** to attach the passenger/right Support Bracket.
24. Carefully unwrap the CS1 HD Bumper. With assistance, position the Bumper up to the inside of the Winch Tray mounts. Temporarily support the weight of the Bumper. **WARNING:** To avoid possible injury or damage to the vehicle, do not proceed until the Bumper is fully and safely supported.
25. Temporarily attach the Bumper to the inside of the mounts with the included (6) 12mm x 35mm Hex Bolts, (6) 12mm Lock Washers and (6) 12mm x 32mm STD Flat Washers, **(Figures 54 & 55)**. Do not fully tighten hardware at this time.
26. Align and level the CS1 Bumper and Winch Tray to the vehicle. Check the fit of all cut panels to match the Bumper. **NOTE:** It may be necessary to remove and install the Bumper a few times to trim the grille assembly for best results. Once all cut panels have been matched up, temporarily remove the Bumper.
27. Fully tighten all grille and factory bumper hardware and fully reattach all bumper panels. Clean up cut sections and push Edge Trim onto the vertically cut sections of the bumper, **(Figures 41 & 42)**. Plug in all wiring harnesses leading to the grille and bumper as described in **Step 4**.
28. Determine if the vehicle is equipped with front bumper sensors. **NOTE:** Sensors and/or LED lights must be installed before installing Bumper assembly.

**Models without bumper sensors:**

- a. From the front of the Bumper, push the included Plugs into the sensor mounts, **(Figure 45)**.

**Models with bumper mounted sensors:**

- a. Select (1) of the (2) inner sensors, **(Figure 46)**.
  - b. Remove the factory sealing washer from the sensor, **(Figure 46)**. Attach the provided Foam Sealing Washer to the front of the sensor, **(Figure 47)**.
  - c. Push the sensor in from the back of the Bumper and snap into place, **(Figure 48)**.
  - d. Repeat the previous **Steps** for the remaining sensor.
29. Determine if accessory lights, (not included), or Screen Fill Panels will be installed at this time.

**IMPORTANT:** Install Center Fill Panels and/or lights before installing Bumper.

**Inner center LED bar style light installation (light not included).**

- a. Select the driver/left "L" Light Bar Bracket, **(Figure 49)**. **NOTE:** "L" Brackets are offset to adjust for different widths of LED Bar Lights and can be installed on either side as needed.
- b. Attach the "L" Bracket to the slot on the back of the Bumper with (1) 8mm x 25mm Hex Bolt, (2) 8mm Flat Washers, (1) 8mm Lock Washer and (1) 8mm Hex Nut, **(Figure 51)**. Repeat this **Step** to install the remaining "L" Bracket on the other side of the Bumper.
- c. Attach the light to the "L" Brackets with the hardware included with the light or the supplied (2) 8mm x 25mm Hex Bolts, (2) 8mm Lock Washers and (2) 8mm Flat Washers, **(Figure 49)**. Do not fully tighten hardware at this time.

**Screen Fill Panel Installation (do not install fill panel if installing light).**

- a. Select Center Screen Fill Panel. Attach Screen Fill Panel to tabs on Bumper with the included (3) 6mm Button Head Combo Bolts and 6mm Flange Nuts, **(Figure 50)**. Attach ends of Fill Panel to previously installed "L" Brackets with (2) 8mm x 25mm Hex Bolts, (4) 8mm Flat

Washers, (2) 8mm Lock Washers and (2) 8mm Hex Nuts, **(Figure 50)**. Fully tighten Fill Panel hardware at this time.

30. Attach the winch cable guide to the front of the Bumper, (winch and cable guide not included).  
**Models with front license plate**, insert the included License Plate Bracket between the cable guide and the front of the Bumper. Attach Bracket to the front of the Tray with (2) 10mm x 30mm Button Head Bolts, (2) 10mm x 20mm Small Flat Washers and (2) 10mm Nylon Lock Nuts, **(Figure 51)**.
31. With assistance, position the Bumper Assembly up to the inside of the Frame Brackets and reinstall Bumper, **(Figures 52 & 53)**. Level and adjust the Bumper and fully tighten all hardware.
32. Attach the outer Mesh Fill Panels to the Bumper with the included (8) 6mm x 20mm Button Head Combo Bolts, **(Figure 54)**. Installation is optional.
33. If front license plate is required, insert (2) Plastic Plugs into the square holes in the License Plate Bracket, **(Figure 54)**. Reuse the factory screws to attach the license plate to the plastic plugs.
34. Do periodic inspections to the installation to make sure that all hardware is secure and tight.

**To protect your investment**, Do not use any type of polish or wax that may contain abrasives that could damage the finish. Mild soap may be used to clean the Front Bumper assembly.

### Driver/left Side Installation Pictured

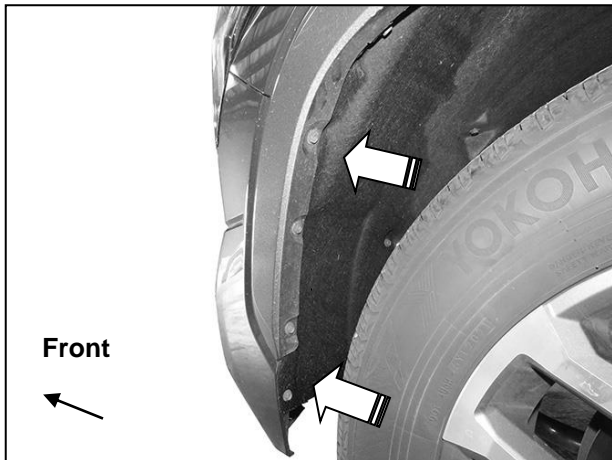

**(Fig 1) Remove hardware attaching fender liner to fender and bumper (arrows)**



**(Fig 2) Models with fender flares, pull end of flare outward to release clips from body**

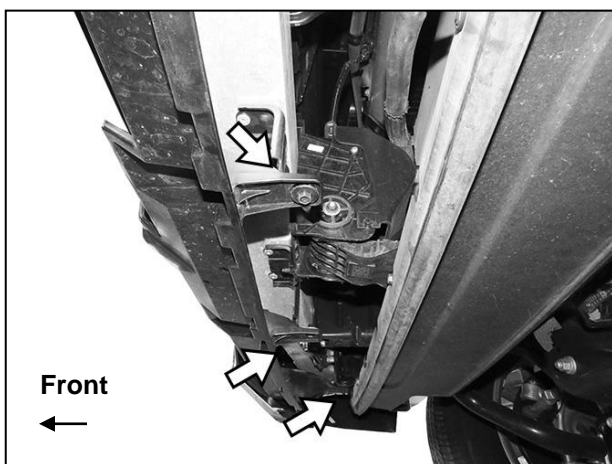

**(Fig 3) Remove all hardware attaching bottom of bumper cover (arrows)**



**(Fig 4) Remove lower cover from bumper**

**Driver/left Side Installation Pictured**



**(Fig 5) Remove center body panel (fascia)**



**(Fig 7) Remove all hardware attaching top of grille and bumper cover to radiator core support (arrows) and remove grille/bumper cover assembly**

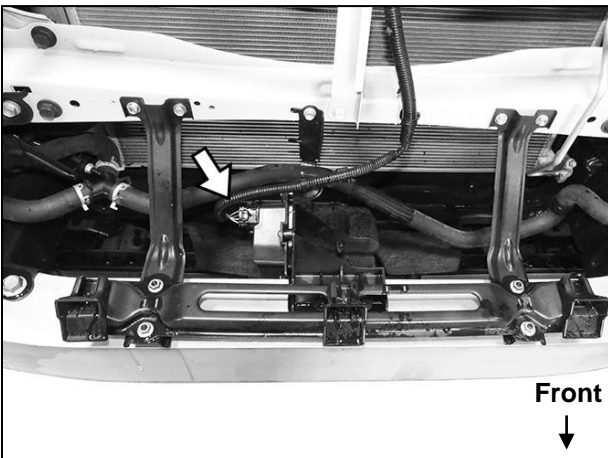

**(Fig 9) Unplug active air dam motor (arrow)**



**(Fig 6) Unplug all wiring harnesses leading to front bumper (passenger/right side pictured)**



**(Fig 8) Grille/bumper cover assembly removed**

**Driver/left Side Installation Pictured**

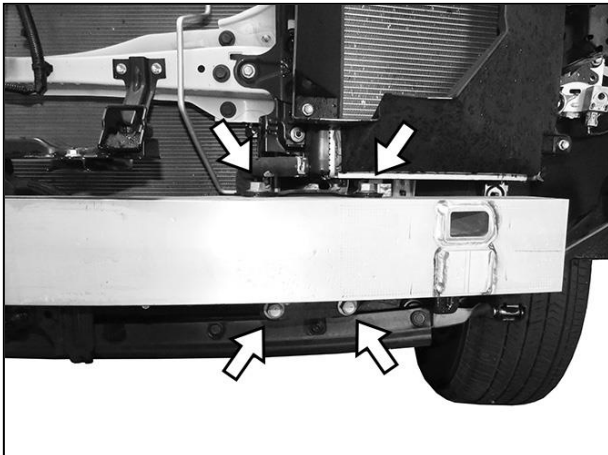

**(Fig 10) Remove aluminum impact bumper from end of frame (arrows-driver/left side pictured)**



**(Fig 11) Bumper, grille and impact bumper removed**

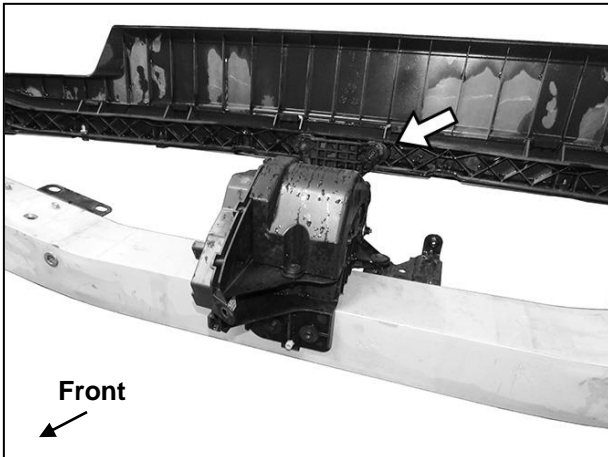

**(Fig 12) Remove active air dam and motor assembly from impact bumper**

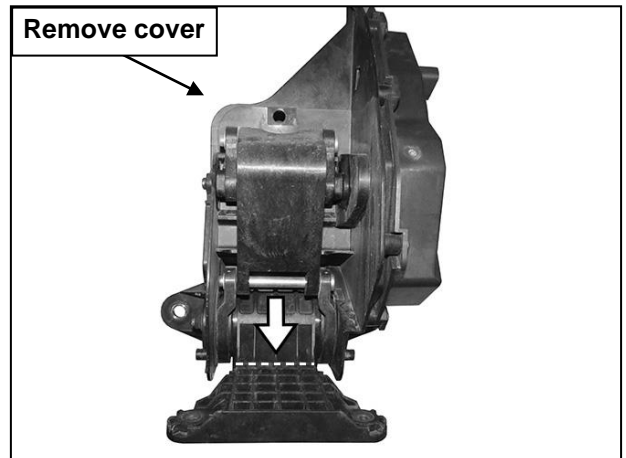

**(Fig 13) Cut mounting tab off of drum (dashed line). Optional, disassemble motor to cut tab off of drum (see Fig 13-18)**



**(Fig 14) Remove long pivot bolt (arrow)**

**Driver/left Side Installation Pictured**



**(Fig 15) Remove outer covers and inner drive from both sides**



**(Fig 16) Remove inner drive spring**

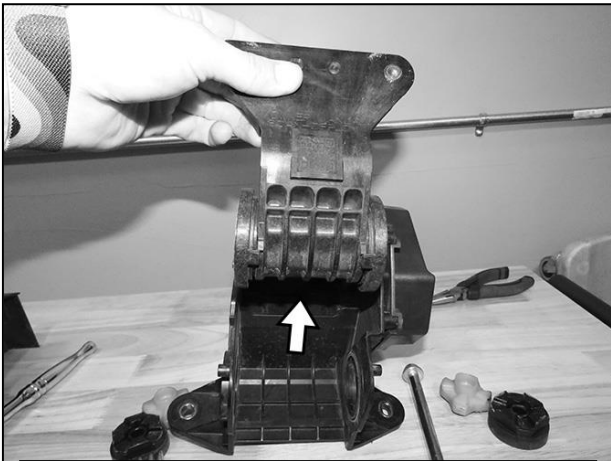

**(Fig 17) Slide air dam bracket out of mount**



**(Fig 18) Slide air dam bracket out of mount**

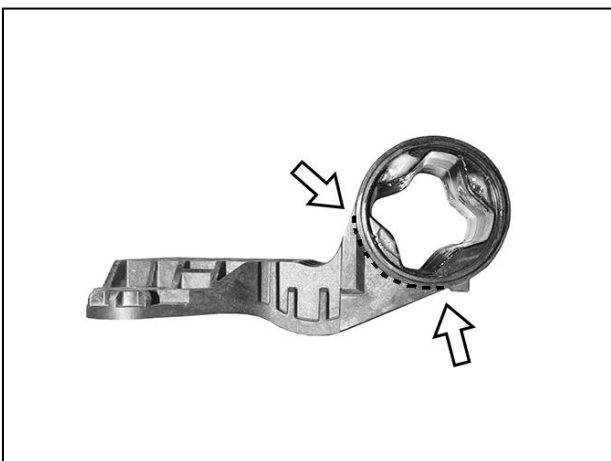

**(Fig 19) Cut bracket off of drum (arrows). Reinstall drum section only**



**Driver/left Side Installation Pictured**

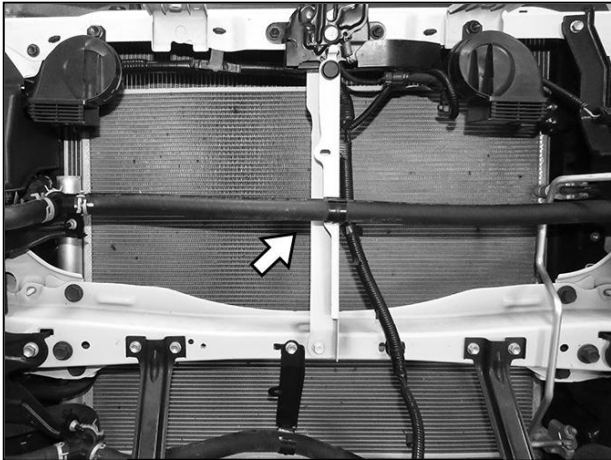

**(Fig 20) Release hose from center support (arrow)**

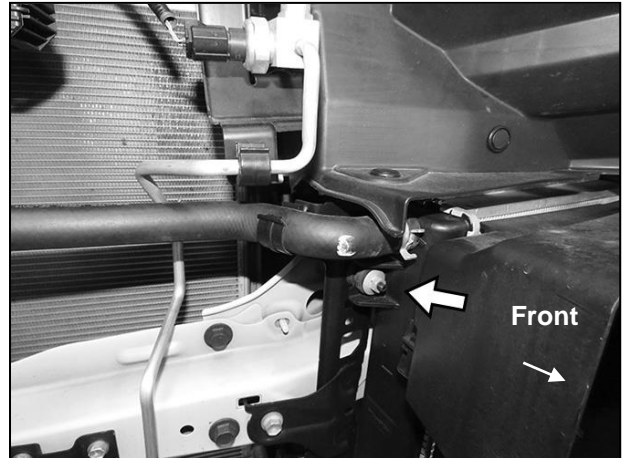

**(Fig 21) Remove hex nut attaching driver/left hose mounting bracket (arrow)**

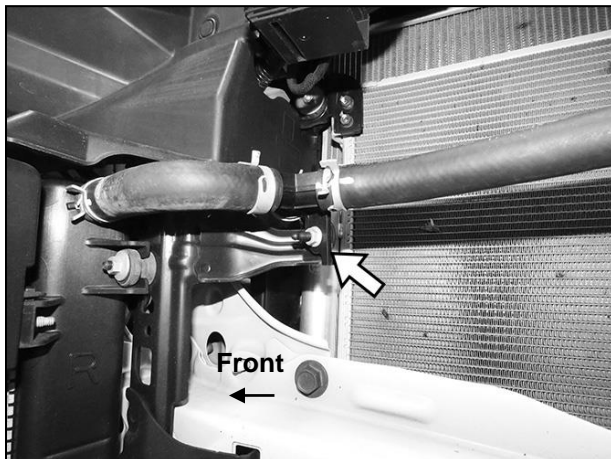

**(Fig 22) Remove hex nut attaching passenger/right hose mounting bracket (arrow)**

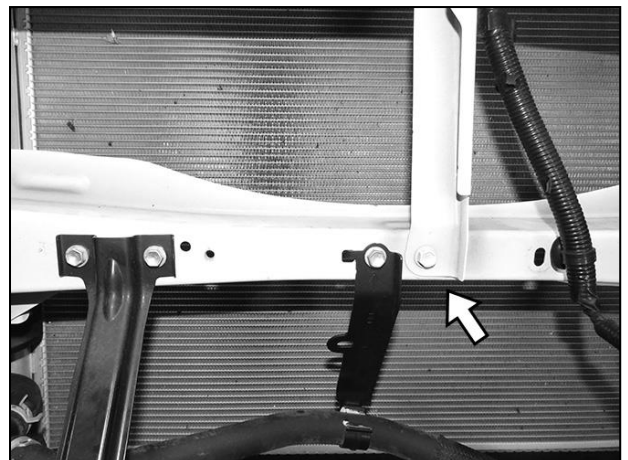

**(Fig 23) Remove hex bolt attaching bottom of center support to crossmember (arrow)**

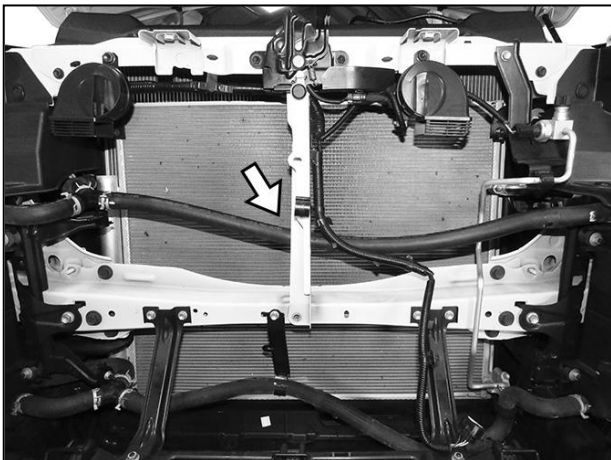

**(Fig 24) Move hose under and behind center support (arrow) Reattach hose brackets**

**Driver/left Side Installation Pictured**

8mm x 50mm Hex Bolt  
(2) 8mm Flat Washers  
8mm Nylon Lock Nut

6mm x 50mm Hex Bolt  
(2) 6mm Flat Washers  
6mm Nylon Lock Nut

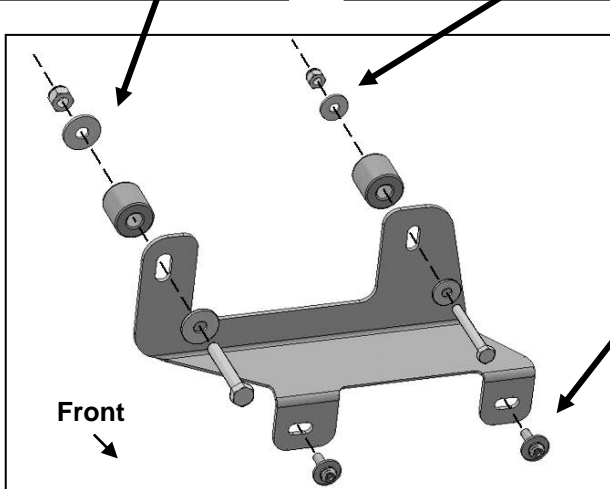

(2) 6mm Button Head Combo Bolts

(Fig 25) Attach air dam motor to back of Relocation Bracket. Insert Spacers between back of Bracket and air dam motor.

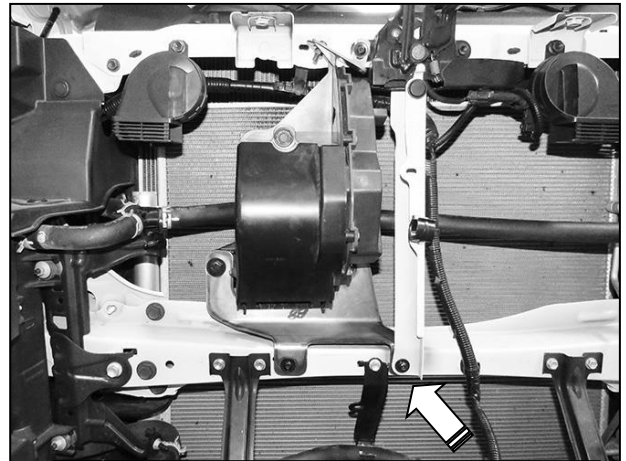

(Fig 26) Attach air dam motor Relocation Bracket to front of crossmember. Insert Bracket between center support and crossmember (arrow)

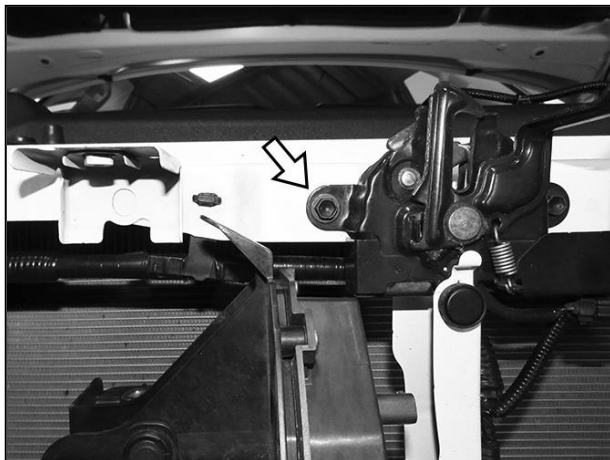

(Fig 27) Remove the hex bolt attaching hood release to core support (arrow)

6mm x 20mm Button Head Bolt  
(2) 6mm Flat Washers  
6mm Nylon Lock Nut

6mm Button Head Combo Bolt

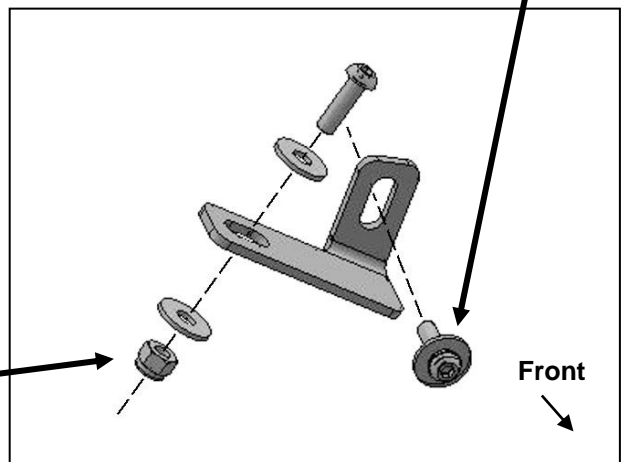

(Fig 28) Attach Top Support Bracket to motor and core support

### Driver/left Side Installation Pictured

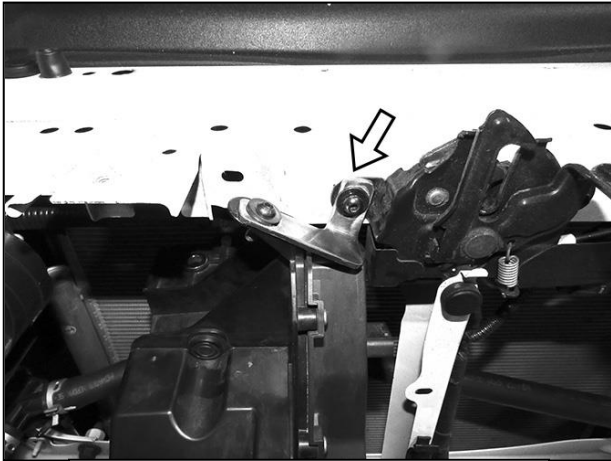

(Fig 29) Attach Top Support Bracket to motor and core support

- 10mm x 35mm Hex Bolt
- (2) 10mm x 34mm Large Flat Washers
- 10mm Lock Washer
- 10mm Hex Nut

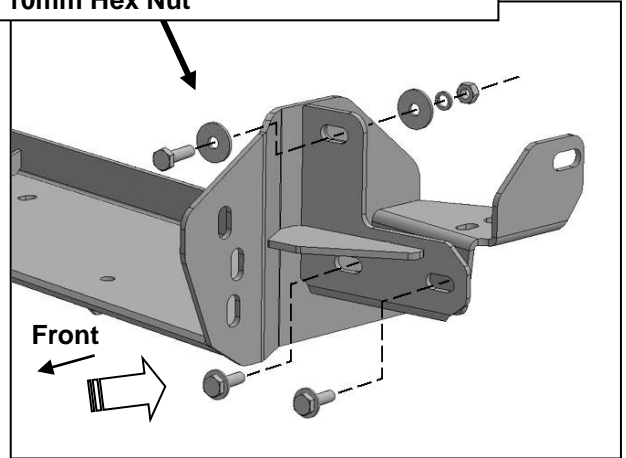

(Fig 30) Reuse (2) factory hex bolts to attach bottom of Winch Tray to end of frame (arrow). Driver/left side of Winch Tray illustrated

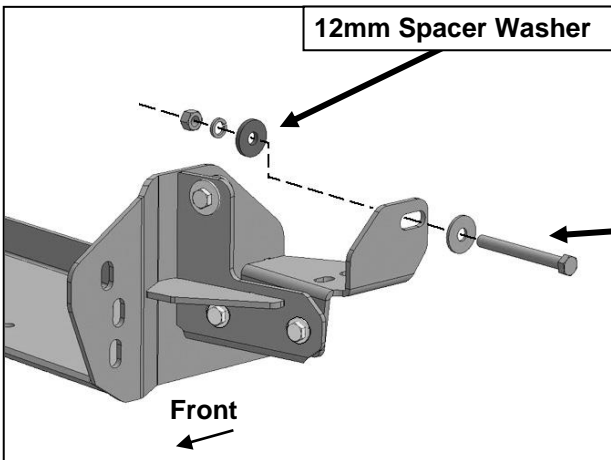

(Fig 31) Attach tab on Winch Tray to side of frame. Driver/left side of Winch Tray illustrated

- 12mm x 110mm Hex Bolt
- 12mm x 37mm Large Flat Washer
- 12mm Lock Washer
- 12mm Hex Nut

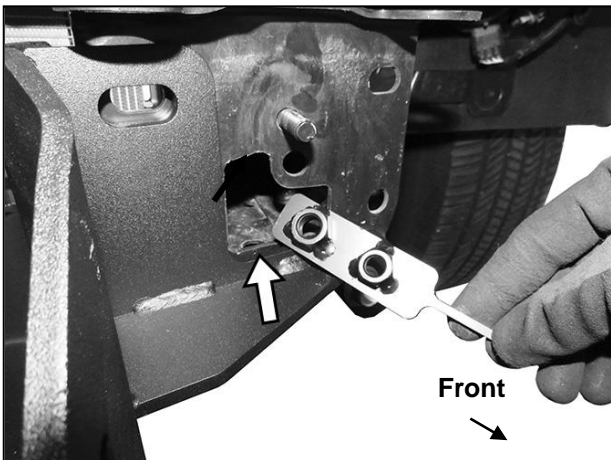

(Fig 33) Insert Double Nut Plate into end of frame. Line up Nut Plate with holes in frame

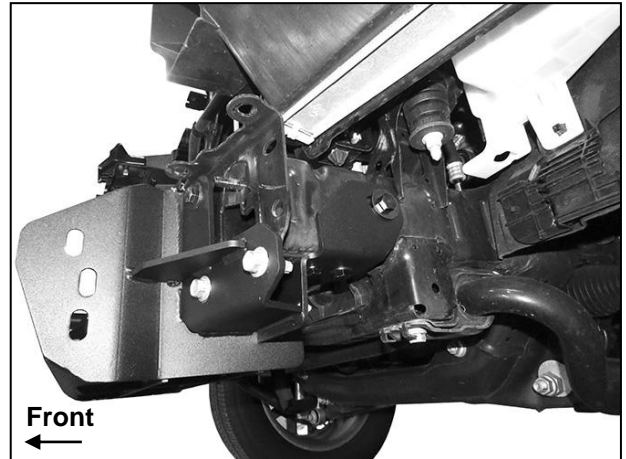

(Fig 32) Driver/left side of Winch Tray installed

**Driver/left Side Installation Pictured**

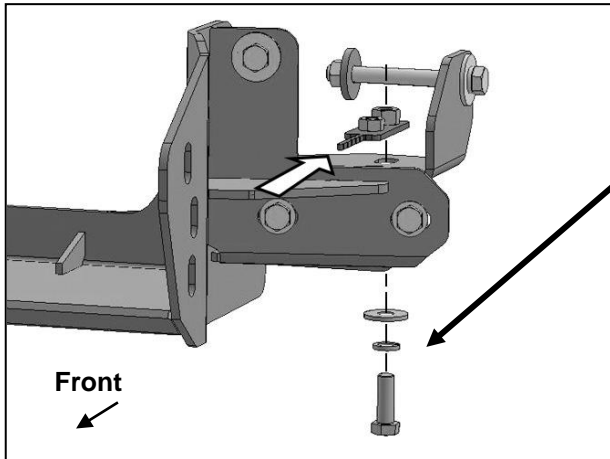

12mm x 35mm Hex Bolt  
12mm Lock Washer  
12mm x 32mm STD Flat Washer

10mm x 35mm Hex Bolt  
10mm Lock Washer  
10mm x 24mm STD Flat Washer

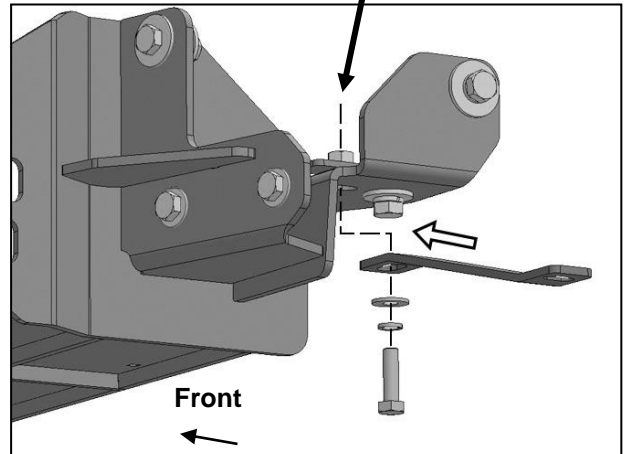

**(Fig 34) Attach Winch Tray to bottom of frame and Nut Plate**

**(Fig 35) Attach inner end of Bumper Support Bracket to bottom of frame and Nut Plate**

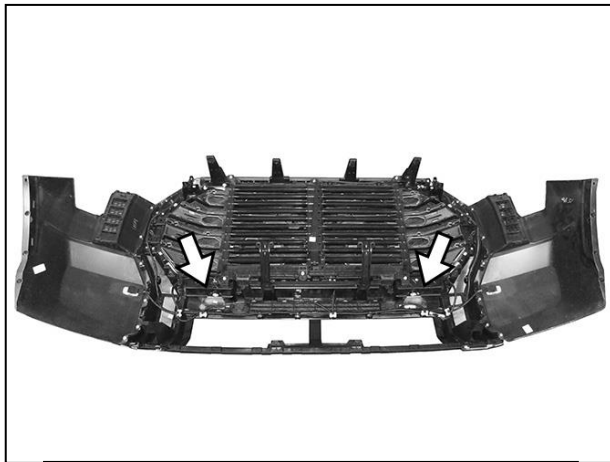

**(Fig 36) Remove inner sensors (arrows). Release wiring harnesses from clips to move before cutting plastic bumper**

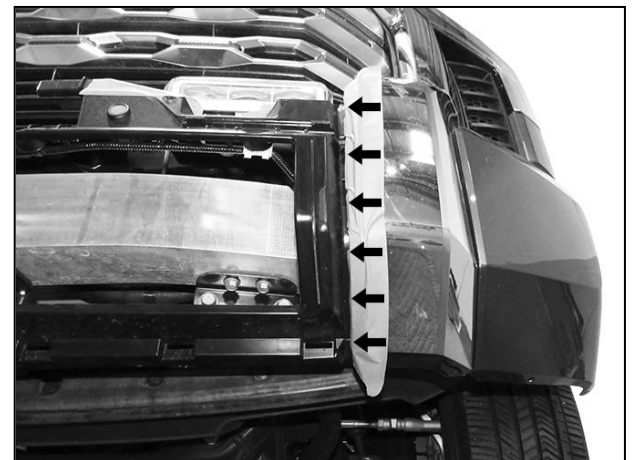

**(Fig 37) Use masking tape to make vertical guide line along bend in inner bumper support**

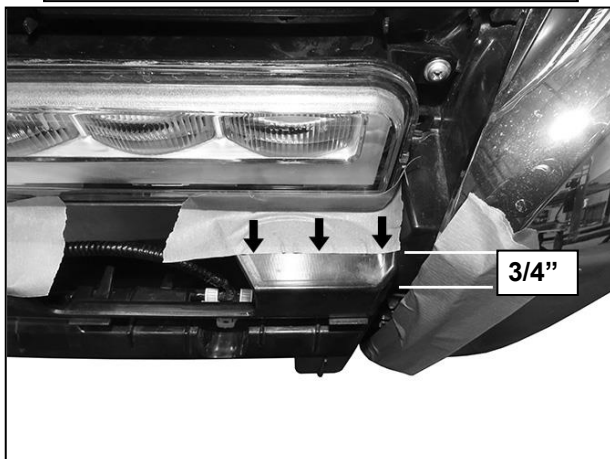

**(Fig 38) From above, mark guide line 3/4" from bent edge on inner bumper support**

**Driver/left Side Installation Pictured**

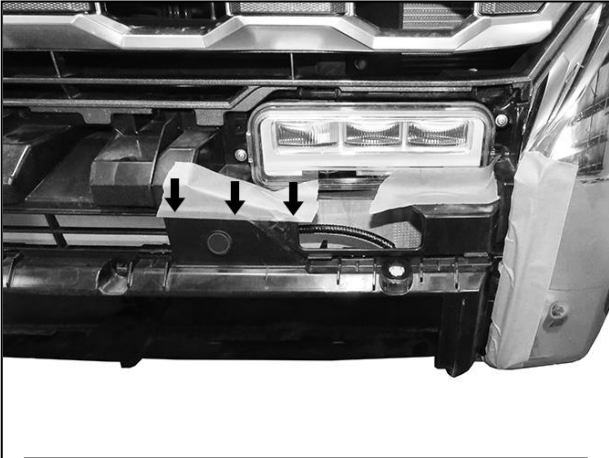

**(Fig 39) Mark guide line along corner edge from edge above parking sensor location**

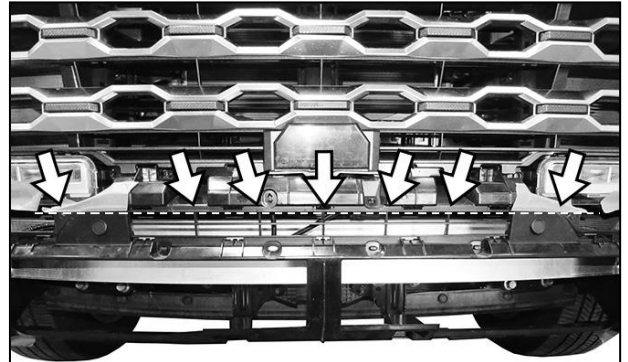

**(Fig 40) Cut straight across top of opening in inner bumper support (arrows)**

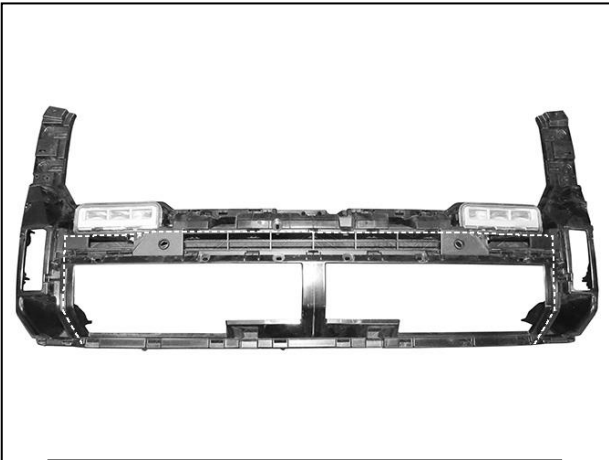

**(Fig 41) Dashed line represents all cut lines on plastic inner bumper support**

**Push Edge Trim onto vertical cut edge of factory bumper support once all adjustments have been made and hardware fully tightened**

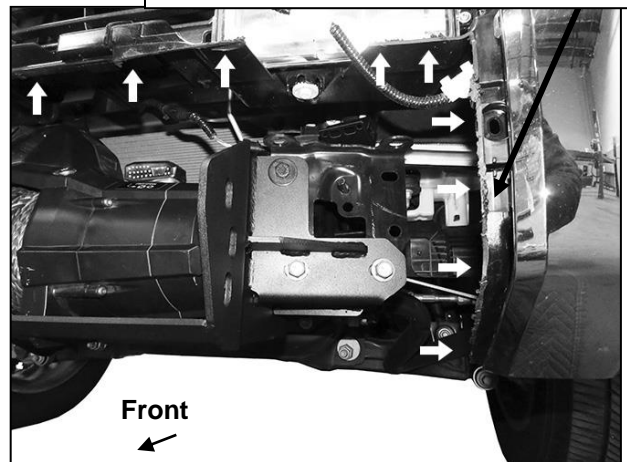

**(Fig 42) Reassemble and install grille and bumper assembly**

**Driver/left Side Installation Pictured**

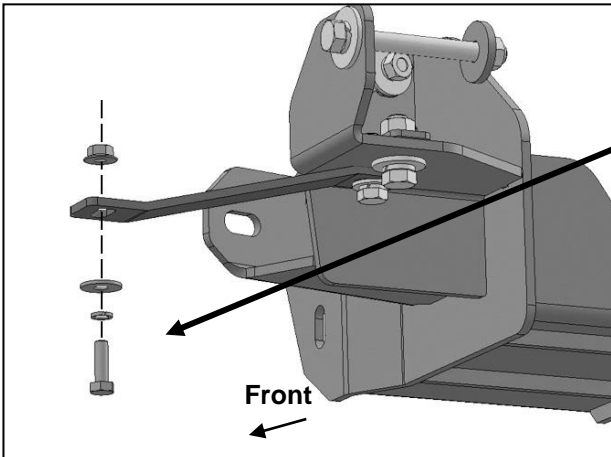

- 8mm x 25mm Hex Bolt
- 8mm Lock Washer
- 8mm Flat Washer
- 8mm Flange Nut

**(Fig 43) Attach outer end of Support Bracket to factory bumper (see Fig 44)**

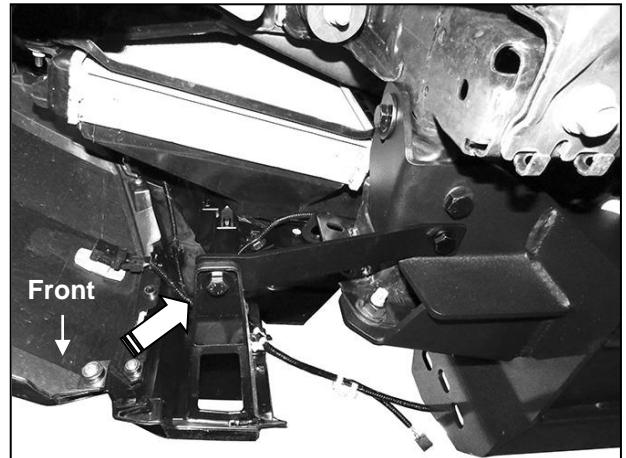

**(Fig 44) Attach outer end of Support Bracket to factory bumper (arrow-also see Fig 43). Driver/left side pictured from behind bumper**

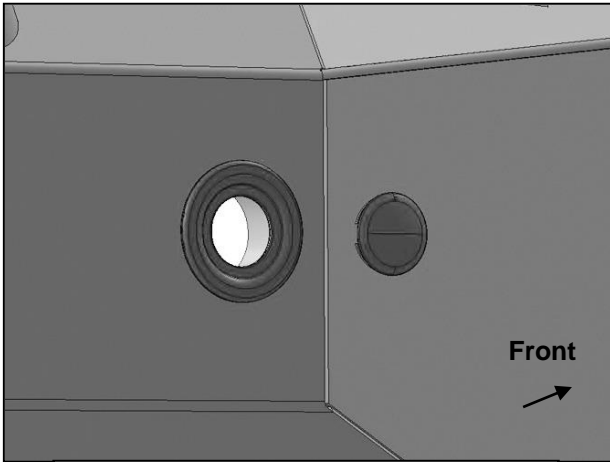

**(Fig 45) Models without front sensors, push sensor plugs into mounts**



**(Fig 47) Apply Foam Seals to end of sensors**

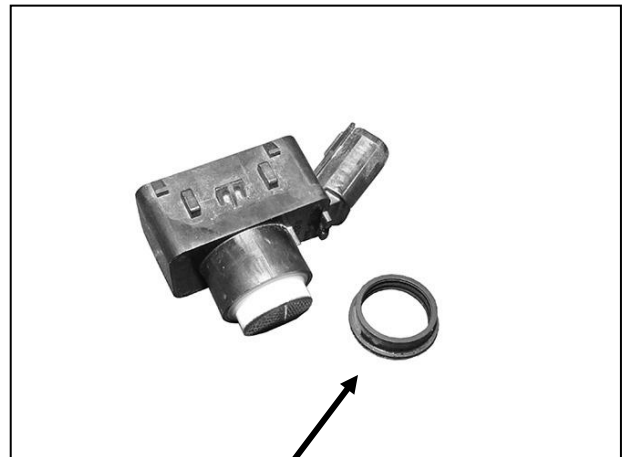

**(Fig 46) Remove bushings from end of sensors**

**Driver/left Side Installation Pictured**

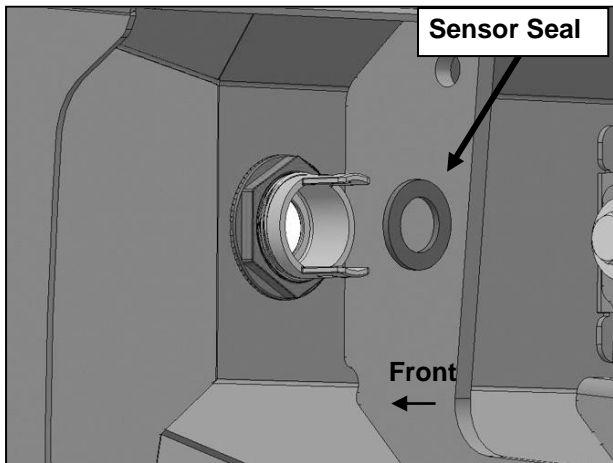

**(Fig 48) Insert sensor assembly through the sensor mount on back of Bumper**

8mm x 25mm Hex Bolt  
(2) 8mm Flat Washers  
8mm Lock Washer  
8mm Hex Nut

6mm Combo Bolts  
6mm Flange Nuts

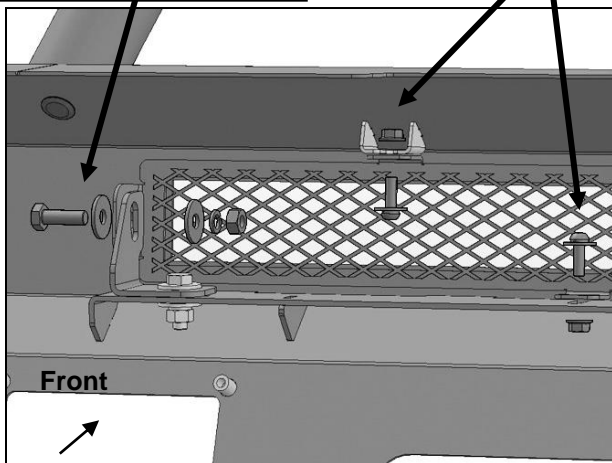

**(Fig 50) Attach Center Fill Panel to "L" Brackets and tabs (Do not install Fill Panel with LED light)**

(2) 10mm x 30mm Button Head Bolts  
(2) 10mm x 20mm Small Flat Washers  
(2) 10mm Nylon Lock Nuts

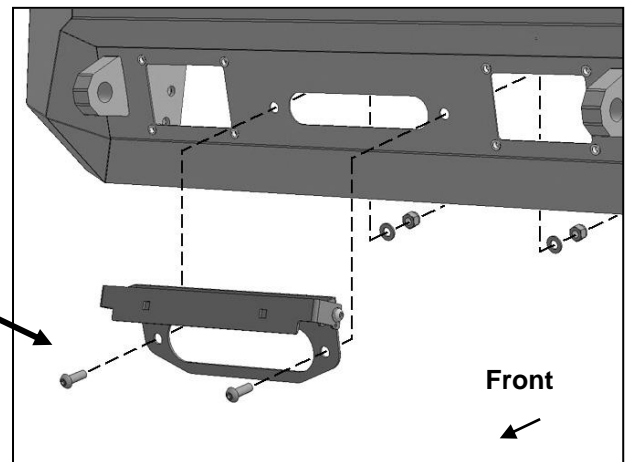

**(Fig 51) Insert License Plate Bracket (if required) between cable guide and Bumper**

8mm x 25mm Hex Bolt  
8mm Lock Washer  
8mm Flat Washer

8mm x 25mm Hex Bolt  
(2) 8mm Flat Washers  
8mm Lock Washer  
8mm Hex Nut

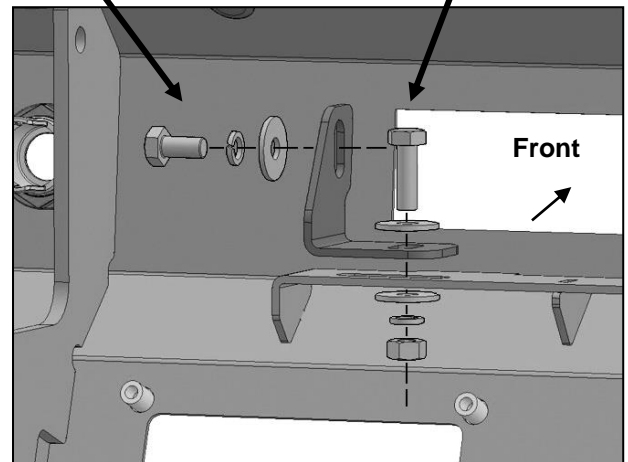

**(Fig 49) Attach "L" Brackets if installing LED center light (not included) or Center Fill Panel**

**Driver/left Side Installation Pictured**

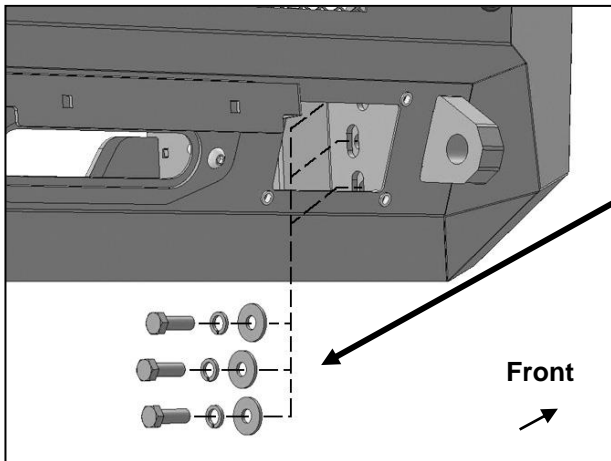

- (3) 12mm x 35mm Hex Bolts
- (3) 12mm Lock Washers
- (3) 12mm x 32mm STD Flat Washers

**(Fig 52) Attach driver/left side of Bumper to inside of Winch Tray**

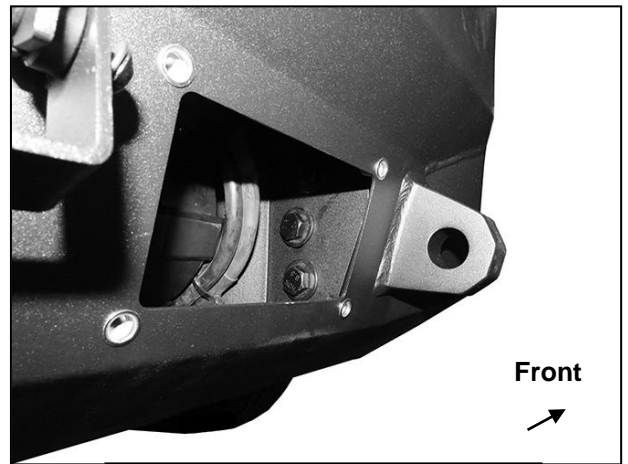

**(Fig 53) Attach driver/left side of Bumper to inside of Winch Tray**

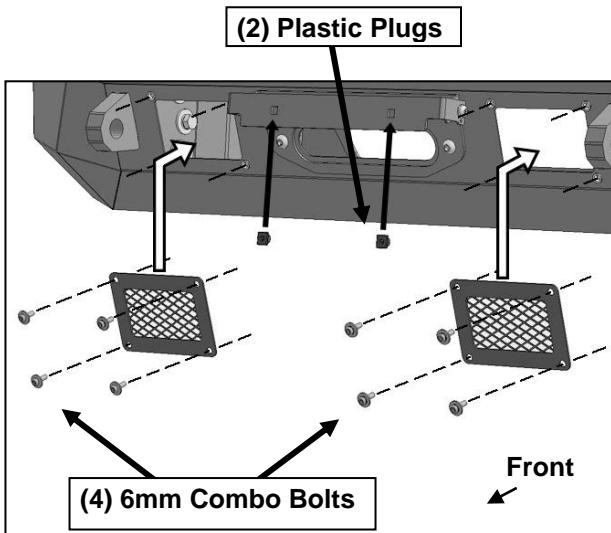

- (2) Plastic Plugs

- (4) 6mm Combo Bolts

**(Fig 54) Attach Mesh Fill Panels (optional). Push in Plastic Plugs for license plate if required**



**Complete Installation. Light, D-Rings and Winch Cable pictured not included**