

1 2 3 4 5 6 7 8

ITEM NO.	PART NUMBER	SW-Configuration Name(Configuration Name)	DESCRIPTION	QTY.
1	14702	Default		1
2	15013-02	Right Hand	Kaw. Ridge 15008 Bumper Mount	1
3	15013-02	Left Hand	Kaw. Ridge 15008 Bumper Mount	1
4	M6-1 Rivet Nut	M6-1 Rivet Nut	(90720A-510)	4
5	.375 Flanged Nylock Nut	.375 Flanged Nylock Nut	Medium-Strength Steel Nylon-Insert Flange Locknut	4
6	.5-13 x 4	.5-13 x 4	Medium-Strength Grade 5 Steel Hex Head Screw	2
7	M6-1x 20mm	M6-1x 20mm	Class 8.8 Steel Flanged Hex Head Screw	4
8	.5 Flat Washer	.5 Flat Washer	Zinc-Plated Steel SAE Washer	4
9	.375 Flat Washer	.375 Flat Washer	Zinc-Plated Steel SAE Washer	20
10	.5-13 Nylock Nut	.5-13 Nylock Nut	High-Strength Steel Nylon-Insert Locknut	2
11	.375-16 x 1 Hex Bolt	.375-16 x 1 Hex Bolt	Medium-Strength Grade 5 Steel Hex Head Screw	4

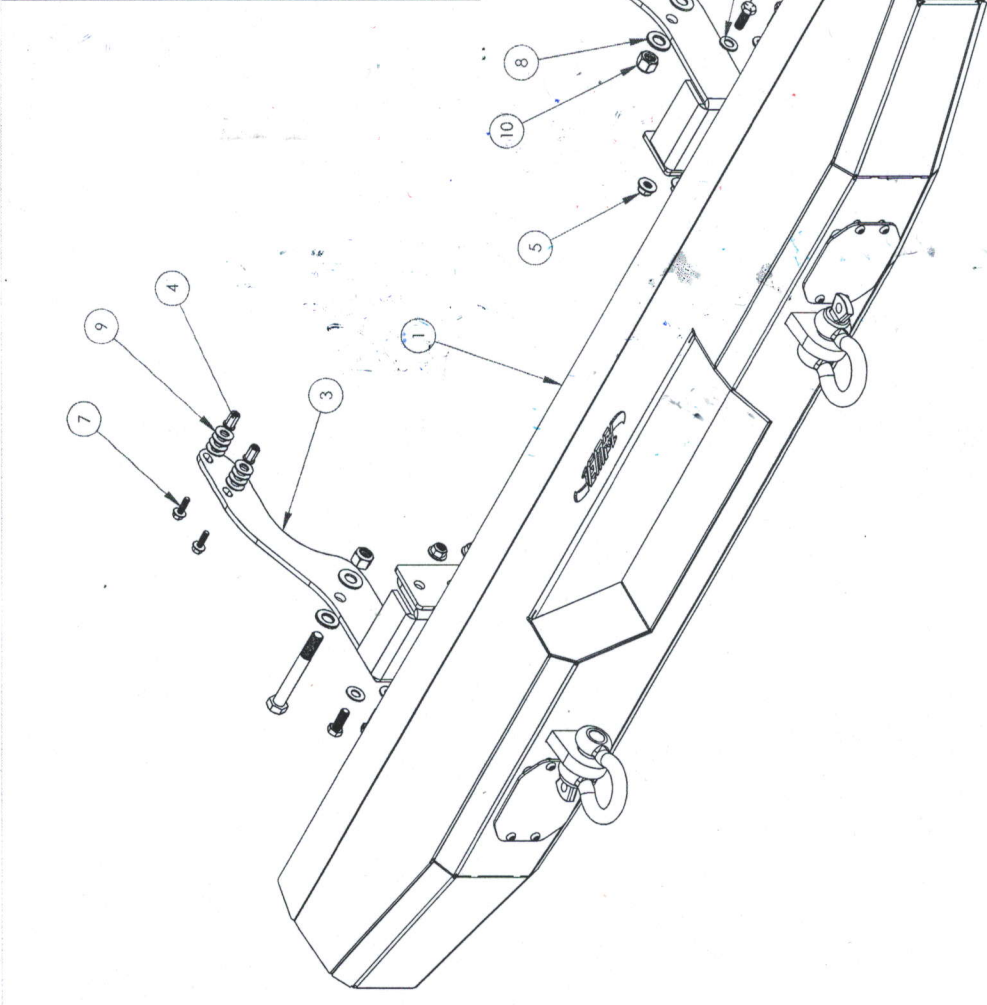

Notes:  
1. Use Item 9 As Needed for Shimming

**Extreme Metal Products, LLC**  
4730 Briar Rd. Cleveland Oh. 44135  
TITLE:  
**Import Kaw. Ridge Bumper**

SIZE DWG. NO. **B 15013-90** REV  
SCALE: 1:5 WEIGHT: 13.3 SHEET 1 OF 1

UNLESS OTHERWISE SPECIFIED:  
DIMENSIONS ARE IN INCHES  
TOLERANCES:  
DRAWN CHECKED  
FRACTIONAL: 1/16  
ANGULAR: MACH. BEND ±  
TWO PLACE DECIMAL ±.005  
THREE PLACE DECIMAL ±.008  
MFG. APPR.  
G.A.  
INTERPRET GEOMETRIC TOLERANCING PER:  
MATERIAL COMMENTS:  
FINISH  
DO NOT SCALE DRAWING

NAME C. DATE 7/3/2024  
DRAWN CHECKED  
FRACTIONAL: 1/16  
ANGULAR: MACH. BEND ±  
TWO PLACE DECIMAL ±.005  
THREE PLACE DECIMAL ±.008  
MFG. APPR.  
G.A.  
INTERPRET GEOMETRIC TOLERANCING PER:  
MATERIAL COMMENTS:  
FINISH  
DO NOT SCALE DRAWING

APPLICATION  
NEXT ASST  
USED ON

**PROPRIETARY AND CONFIDENTIAL**  
THE INFORMATION CONTAINED IN THIS DRAWING IS THE SOLE PROPERTY OF EXTREME METAL PRODUCTS, LLC. REPRODUCTION IN PART OR AS A WHOLE WITHOUT THE WRITTEN PERMISSION OF EXTREME METAL PRODUCTS, LLC IS PROHIBITED.

D B A