

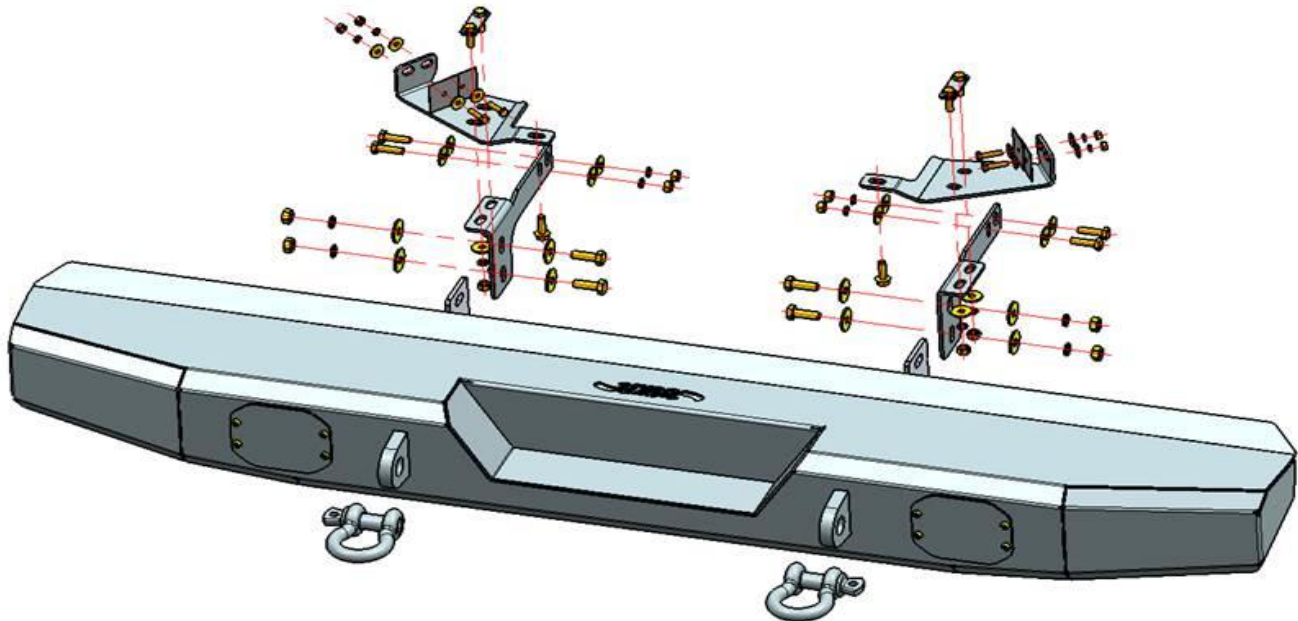

Ranger XP1000 Extreme Rear Bumper P/N: 15008

PARTS LIST:

1	Rear Bumper	2	8-1.25mm x 25mm Special Self Tapping Hex Bolts
1	Driver/left Frame Bracket	4	8-1.25mm x 30mm Hex Bolts
1	Passenger/right Frame Bracket	12	8mm x 24mm x 2mm Flat Washers
1	Driver/left Support Bracket	8	8mm Lock Washers
1	Passenger/right Support Bracket	8	8mm Hex Nuts
4	10-1.5mm x 30mm Hex Bolts	4	6-1.0mm x 25mm Hex Bolts
8	10mm x 30mm x 2.5mm Flat Washers	8	6mm x 18mm x 1.6mm Flat Washers
4	10mm Lock Washers	4	6mm Lock Washers
4	10mm Hex Nuts	4	6mm Hex Nuts
2	8-1.25mm x 25mm Double Bolt Plates		



PROCEDURE:

REMOVE CONTENTS FROM BOX. VERIFY ALL PARTS ARE PRESENT. READ INSTRUCTIONS CAREFULLY BEFORE STARTING INSTALLATION. ASSISTANCE IS RECOMMENDED TO AVOID POSSIBLE INJURY OR DAMAGE TO THE VEHICLE.

1. Select the driver/left Support Bracket and (1) 8mm Double Bolt Plate, **(Figure 1)**. Insert the threaded end of the Double Bolt Plate down through the (2) holes in the center of the Support Bracket. Hold the Bracket up to the bottom of the frame. The Bracket will attach to the angled brace on the bottom of the bed and to the rear crossmember.
2. Attach the front tab on the Support Bracket to the side of the angled brace with the included (2) 6mm x 25mm Hex Bolts, (4) 6mm Flat Washers, (2) 6mm Lock Washers and (2) 6mm Hex Nuts, **(Figure 2)**. Attach the single bent tab on the Bracket to the hole in the rear crossmember with the included (1) 8mm x 25mm **Special Self Tapping Bolt**, **(Figures 1 & 3)**. **IMPORTANT:** The Self Tapping Bolts feature cutting edges to thread into the hole in the crossmember, only use the Self Tapping Bolts in the rear crossmember. Do not fully tighten hardware at this time.
3. Next, select the driver/left Frame Mounting Bracket, **(Figure 4)**. Attach the front of the Mounting Bracket to outside of the end of the bed frame with the included (2) 8mm x 25mm STD Hex Bolts, (4) 8mm Flat

Washers, (2) 8mm Lock Washers and (2) 8mm Hex Nuts. Attach the rear of the Mounting Bracket to the bottom of the Support Bracket and 8mm Double Bolt Plate with the included (2) 8mm Flat Washers, (2) 8mm Lock Washers and (2) 8mm Hex Nuts, **(Figures 4 & 5)**. Do not fully tighten hardware.

4. Repeat **Steps 1—3** to install the passenger/right Support and Frame Brackets, **(Figures 6 & 7)**. **IMPORTANT:** Allow exhaust to fully cool before installing passenger/right side Brackets.
5. With assistance, position the Bumper Assembly up to the outside of the Frame Brackets, **(Figure 8)**. Temporarily support the weight of the Bumper. **WARNING:** To avoid possible injury or damage to the vehicle, do not proceed until the Bumper is fully and safely supported.
6. Attach the driver/left side of the Bumper to the outside of the Bracket with the included (2) 10mm x 30mm Hex Bolts, (4) 10mm Flat Washers, (2) 10mm Lock Washers and (2) 10mm Hex Nuts, **(Figures 8 & 9)**. Do not fully tighten hardware. Repeat to attach the passenger/right side of the Bumper.
7. Level and adjust the Bumper and fully tighten all hardware.
8. Locate the mounting slots in the tabs on the back of the Bumper to install lights if desired. **NOTE:** Lights not included.
9. Do periodic inspections to the installation to make sure that all hardware is secure and tight.

To protect your investment, Do not use any type of polish or wax that may contain abrasives that could damage the finish. Mild soap may be used to clean the Bumper assembly.

Driver/left side installation pictured

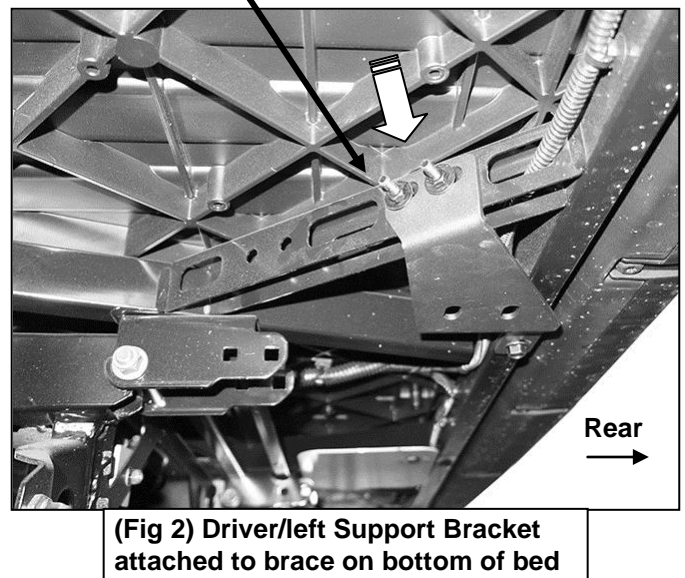
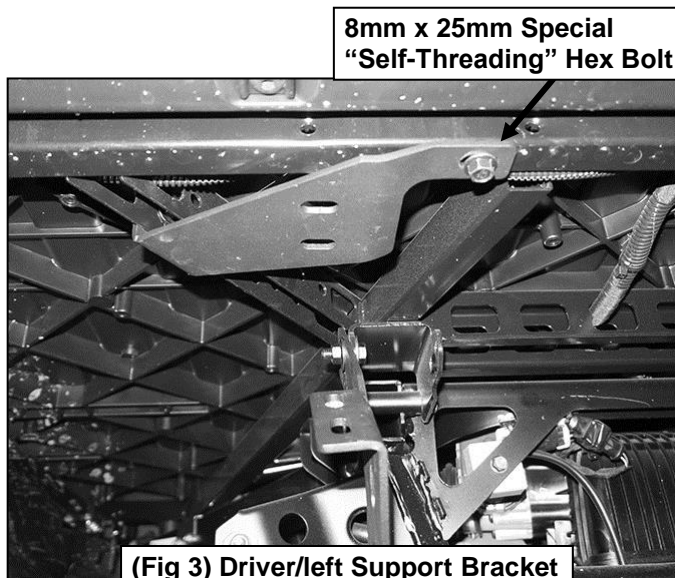
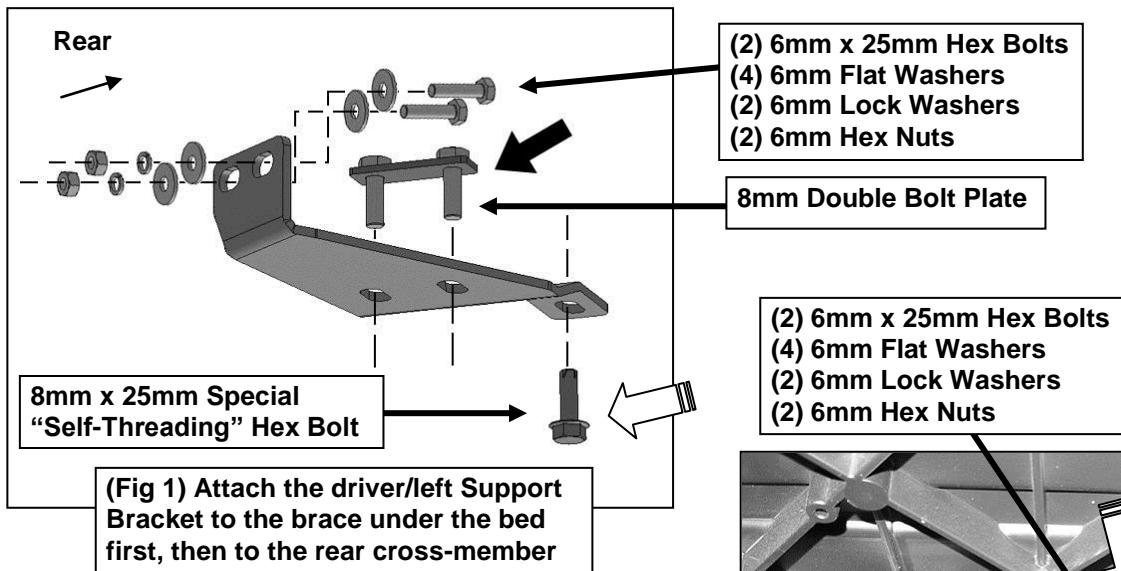

Driver/left side installation pictured

- (2) 8mm x 30mm Hex Bolts
- (4) 8mm Flat Washers
- (2) 8mm Lock Washers
- (2) 8mm Hex Nuts

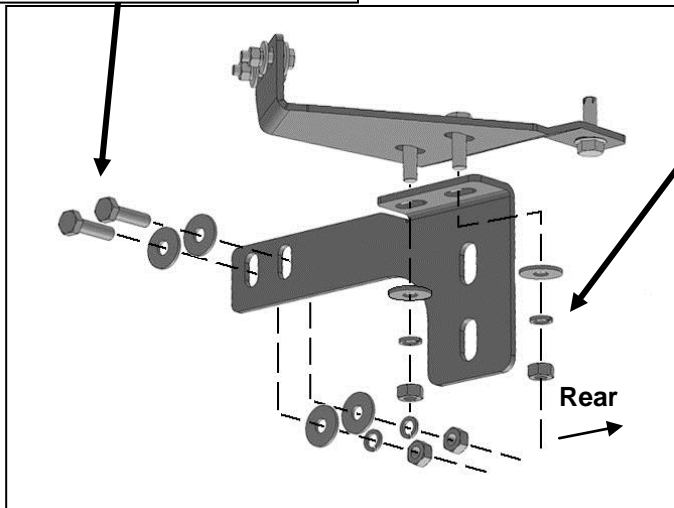

- (2) 8mm Flat Washers
- (2) 8mm Lock Washers
- (2) 8mm Hex Nuts

(Fig 4) Attach driver/left Mounting Bracket to end of frame and bottom of Support Bracket

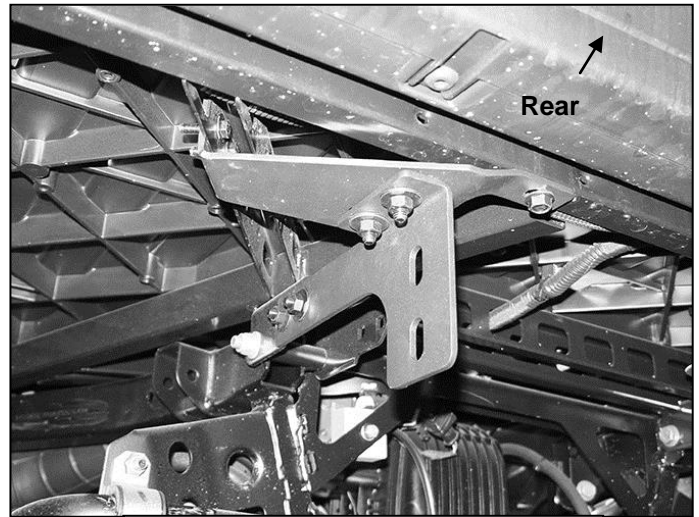

(Fig 5) Driver/left Brackets installed

- (2) 6mm x 25mm Hex Bolts
- (2) 6mm Flat Washers



(Fig 6) Attach the passenger/right Support Bracket to the brace under the bed first, (arrow) then to the rear cross-member

Driver/left side installation pictured

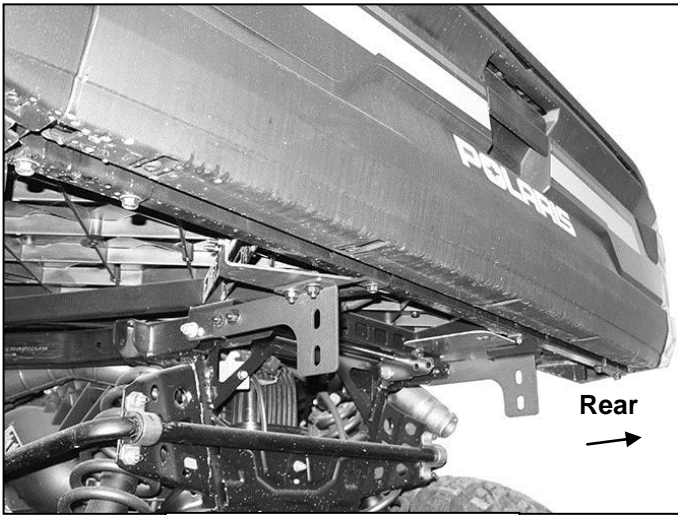

(Fig 7) Brackets installed

- (2) 10mm x 30mm Hex Bolts**
- (4) 10mm Flat Washers**
- (2) 10mm Lock Washers**
- (2) 10mm Hex Nuts**

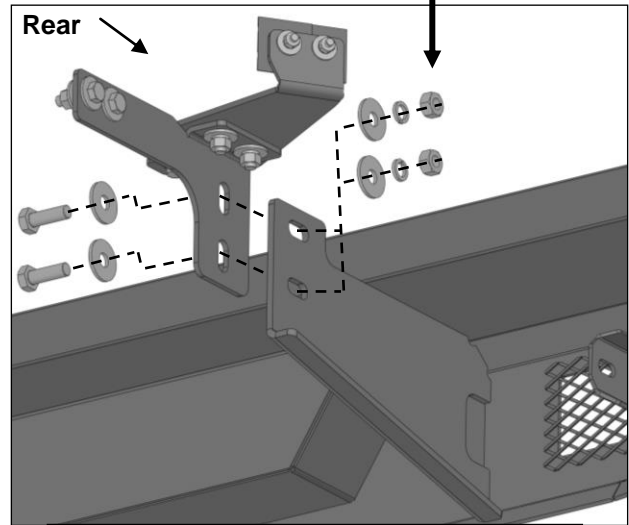

(Fig 8) Attach driver/left side of Bumper to outside of Mounting Brackets

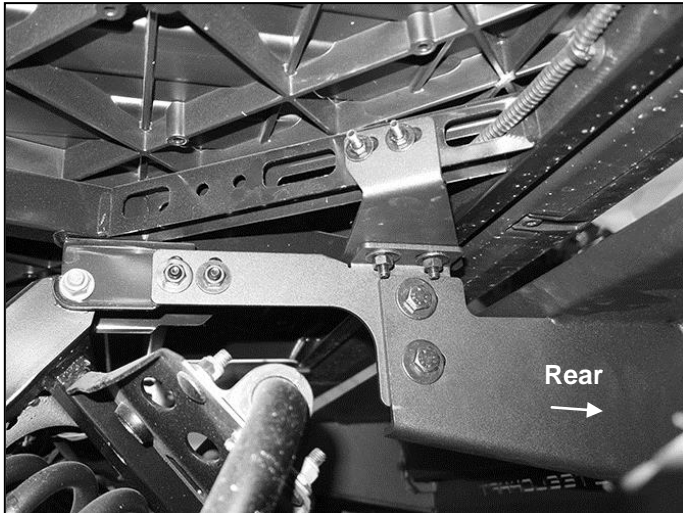

(Fig 9) Driver/left side of Bumper installed