

Drill Template for wiper/washer kit

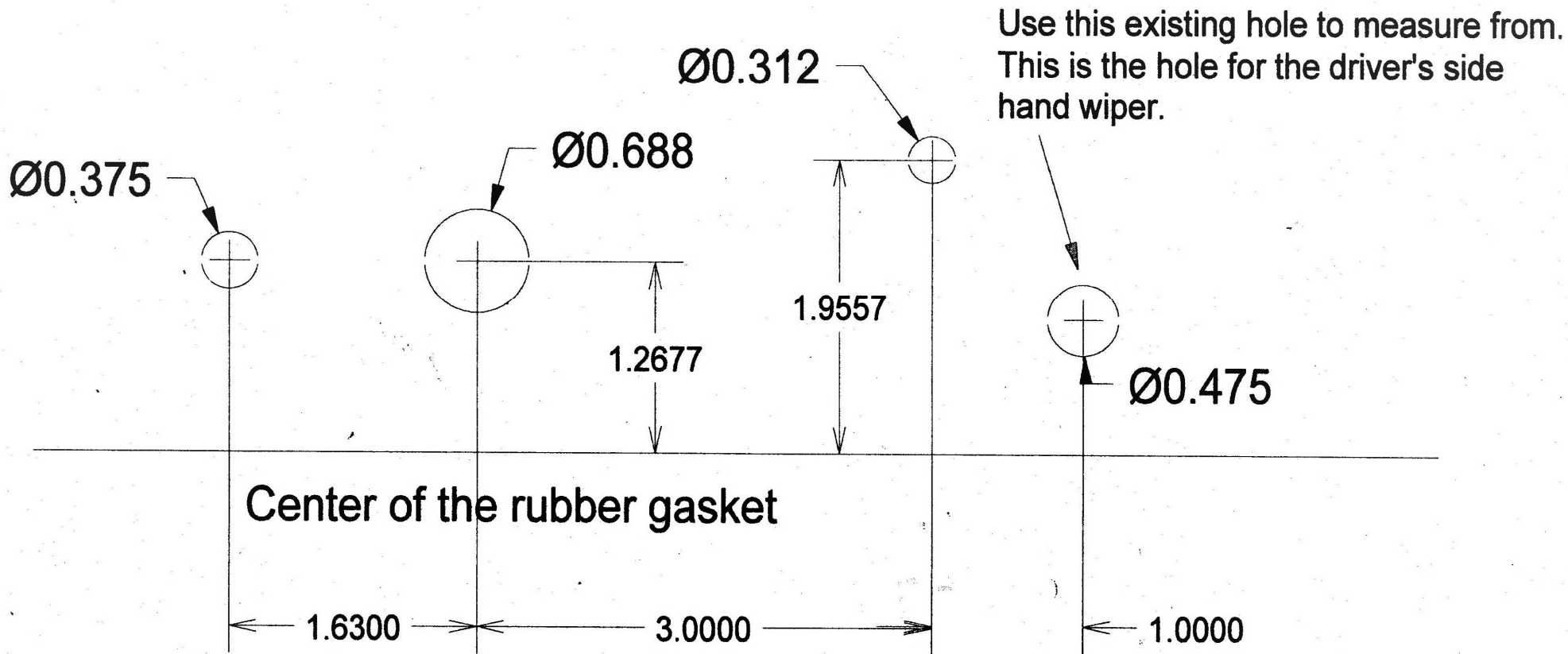

If using this for a drill template check the scale before drilling.
The 1" dimension should be 1" when you measure it.

Template for drilling holes for X3 Windshield Wiper/Washer kit
Retrofit for the EMP® Glass Windshield P/N 13563

Reference:

- (2) .475" diameter holes are for the hand wipers and should already be in our frame.
- (1) .375" diameter hole is for the washer hose. This location is not too critical.
- (1) .688 diameter hole is for the wiper motor shaft.
- (1) .312 diameter hole is for the M6 bolt that stabilizes the wiper motor from rotating.

NOTE: The centers between the .688" and .312 holes is critical.

The line is to the center of the rubber gasket.